



JHW6CN55T02
55T Locking Nut Cylinder 2" Stroke





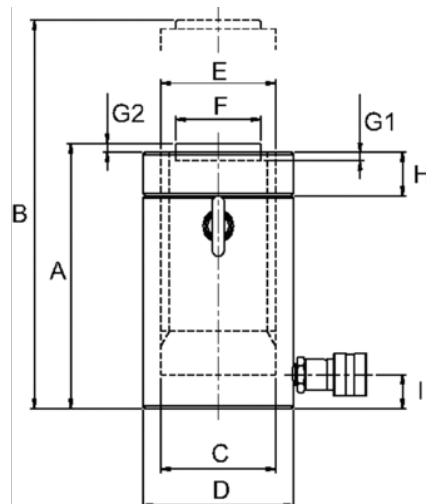

PRODUCT DETAILS

- Single acting cylinder with mechanical safety lock nut
- Designed to support load for extended periods without hydraulic pressure
- Overflow port prevents cylinders from over travel
- Load return
- Solid steel cylinder body
- Ideal for lifting and holding loads



PRODUCT ATTRIBUTES

Product: **JHW6CN55T02**

| | | | | | |
|---|-----------------------|---|---------|---|----------|
|  | 55 t |  | 1.97 in |  | 10.99 in |
|  | 21.65 in ³ | A | 6.5 in | B | 8.4 in |
| C | 3.7 in | D | 4.9 in | F | 2.8 in |
| lb | 34 lb |  | Tw95-6N | G1 | 0.08 in |
| G2 | 0.51 in | H | 1.4 in | I | 1.1 in |