



JHW6CL50T02
50 Ton Low Profile Cylinder





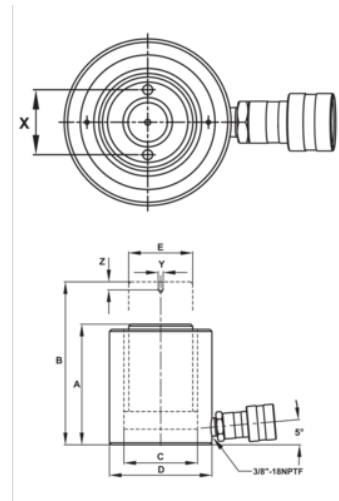

PRODUCT DETAILS

- Compact design for use in confined spaces
- Rod wiper helps seal out dirt and contamination
- Specially designed return spring ensures a quick retraction and extends the life of the spring
- Industrial hard chrome plated ram helps prevent scratching and corrosion
- Plunger end is grooved to reduce load slippage
- Includes high flow ball coupler and dust cap



PRODUCT ATTRIBUTES

Product: **JHW6CL50T02**

	50 t		2.36 in		9.87 in
PSI	10132 psi		23.29 in ³	A	4.8 in
B	7.17 in	C	4.88 in	D	3.54 in
E	2.76 in	X	1.56 in	Y	M5 in
Z	0.32 in				