



JHW5HS1S60
Single Cut Speed Heavy Duty H& Pump





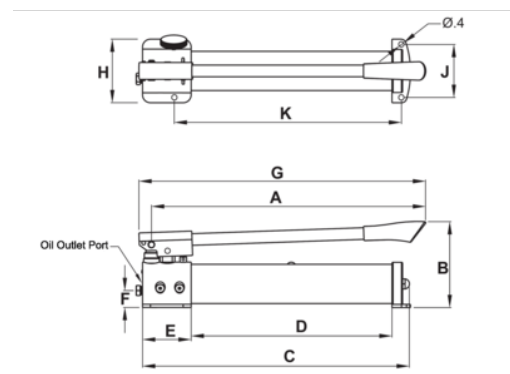

PRODUCT DETAILS

- 5HS2S35, 5HS2S100 and 5HS2S200 feature 2 speed operation
- Pressure relief valve for overload protection
- Load release valve for single acting cylinder usage
- Large oil capacities to power a wide range of cylinders and tools
- 5HS2S35 and 5HS2S1 are constructed of high strength lightweight aluminum alloy for easy handling and corrosion resistance
- All hand pumps function in horizontal positions and will also function in some vertical positions



PRODUCT ATTRIBUTES

Product: **JHW5HS1S60**

	36.5 in ³	PSI		PSI	10.000 psi
			0.15 in ³	lb	109 lb
	0.79 in		3/8" - 18NPTF mm	A	18.94 in
B	6.46 in	C	19.53 in	D	15.35 in
E	1.57 in	F	1.26 in	H	5.2 in
J	3.74 in	K	14.45 in		