



## 5HS Hand Pumps







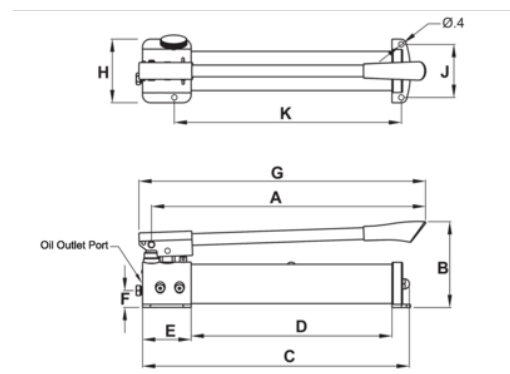

### PRODUCT DETAILS

- 5HS2S35, 5HS2S100 and 5HS2S200 feature 2 speed operation
- Pressure relief valve for overload protection
- Load release valve for single acting cylinder usage
- Large oil capacities to power a wide range of cylinders and tools
- 5HS2S35 and 5HS2S1 are constructed of high strength lightweight aluminum alloy for easy handling and corrosion resistance
- All hand pumps function in horizontal positions and will also function in some vertical positions









PRODUCT ATTRIBUTES







Product: **JHW5HS1S120**

	67 in <sup>3</sup>	<b>PSI</b>		<b>PSI</b>	10.001 psi
			0.13 in <sup>3</sup>		89 lb
	0.82 in		3/8"-18NPTF mm	<b>A</b>	20.5 in
<b>B</b>	6.5 in	<b>C</b>	21.75 in	<b>D</b>	17.5 in
<b>E</b>	2.13 in	<b>F</b>	1.75 in	<b>H</b>	5.25 in
<b>J</b>	3.74 in	<b>K</b>	21.25 in		







Product: **JHW5HS1S60**

	36.5 in <sup>3</sup>	<b>PSI</b>		<b>PSI</b>	10.000 psi
			0.15 in <sup>3</sup>		109 lb
	0.79 in		3/8"-18NPTF mm	<b>A</b>	18.94 in
<b>B</b>	6.46 in	<b>C</b>	19.53 in	<b>D</b>	15.35 in
<b>E</b>	1.57 in	<b>F</b>	1.26 in	<b>H</b>	5.2 in
<b>J</b>	3.74 in	<b>K</b>	14.45 in		







Product: **JHW5HS2S100**

	61 in <sup>3</sup>	<b>PSI</b>	200 psi	<b>PSI</b>	10.003 psi
	0.81 in <sup>3</sup>		0.14 in <sup>3</sup>		132 lb
	0.82 in		3/8"-18NPTF mm	<b>A</b>	19.69 in
<b>B</b>	6.38 in	<b>C</b>	19.88 in	<b>D</b>	14.96 in
<b>E</b>	3.62 in	<b>F</b>	1.26 in	<b>H</b>	4.72 in
<b>J</b>	3.94 in	<b>K</b>	16.93 in		

Product: **JHW5HS2S200**

	128 in <sup>3</sup>	<b>PSI</b>	200 psi	<b>PSI</b>	10.004 psi
	0.81 in <sup>3</sup>		0.14 in <sup>3</sup>		132 lb
	0.82 in		3/8"-18NPTF mm	<b>A</b>	19.75 in
<b>B</b>	6.64 in	<b>C</b>	23.69 in	<b>D</b>	18.37 in
<b>E</b>	2.36 in	<b>F</b>	1.73 in	<b>H</b>	4.72 in
<b>J</b>	3.54 in	<b>K</b>	22.56 in		

Product: **JHW5HS2S35**

	21.4 in <sup>3</sup>	<b>PSI</b>	200 psi	<b>PSI</b>	10.002 psi
	0.18 in <sup>3</sup>		0.05 in <sup>3</sup>		88 lb
	0.38 in		1/4"-18NPTF mm	<b>A</b>	13.43 in
<b>B</b>	5.91 in	<b>C</b>	13.89 in	<b>D</b>	9.09 in
<b>E</b>	2.36 in	<b>F</b>	1.34 in	<b>H</b>	3.35 in
<b>J</b>	2.56 in	<b>K</b>			